

**PLAN VIEW**

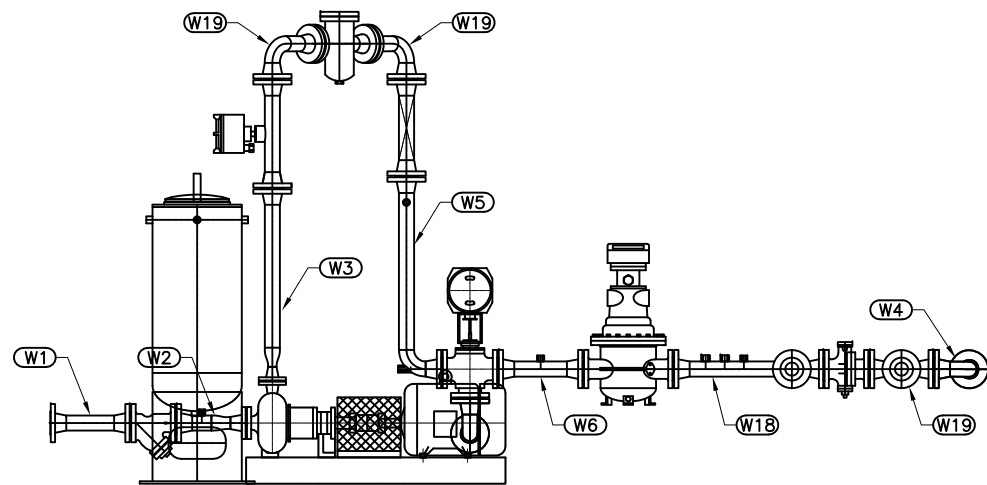

**ELEVATION**

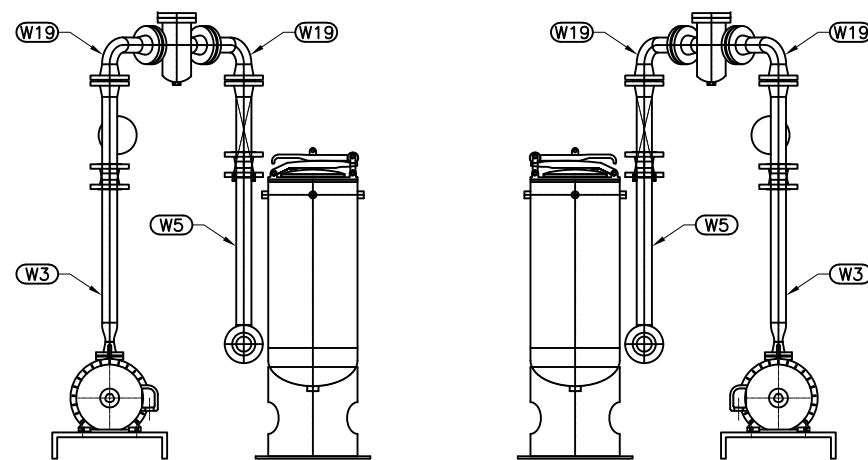

**END VIEW**

| NO. | GENERAL NOTES              | REFERENCE NUMBER | REFERENCE DRAWING | REV. | DATE | REVISION | DRAWN | CHK'D | APPR. |
|-----|----------------------------|------------------|-------------------|------|------|----------|-------|-------|-------|
| 1.  | ALL DIMENSIONS IN INCHES   |                  |                   | A    |      |          |       |       |       |
| 2.  | MATERIAL = VARIES          |                  |                   | B    |      |          |       |       |       |
| 3.  | GENERAL TOLERANCES = ±1/8" |                  |                   | C    |      |          |       |       |       |
| 4.  |                            |                  |                   | D    |      |          |       |       |       |
| 5.  |                            |                  |                   | E    |      |          |       |       |       |
| 6.  |                            |                  |                   | F    |      |          |       |       |       |
| 7.  |                            |                  |                   | G    |      |          |       |       |       |



3421 N. SYLVANIA AVE.  
FORT WORTH, TX 76111  
(817) 744-8242  
FAX (817) 744-8243  
www.-----com

|               |               |
|---------------|---------------|
| CLIENT:       | RESOURCES     |
| SCALE: N.T.S. | DRAWN: DDF    |
| CHECKED: -    | DATE: 9/18/13 |

|        |  |
|--------|--|
| TITLE: | 2" - 150# ANSI LACT UNIT<br>PROCESS PIPING<br>ASSEMBLY & DETAILS |
| SHEET  | UMC-50195-PPA  |